

Operating Instructions

Panasonic

Lens I/F Card

Model No. **AW-PB308**

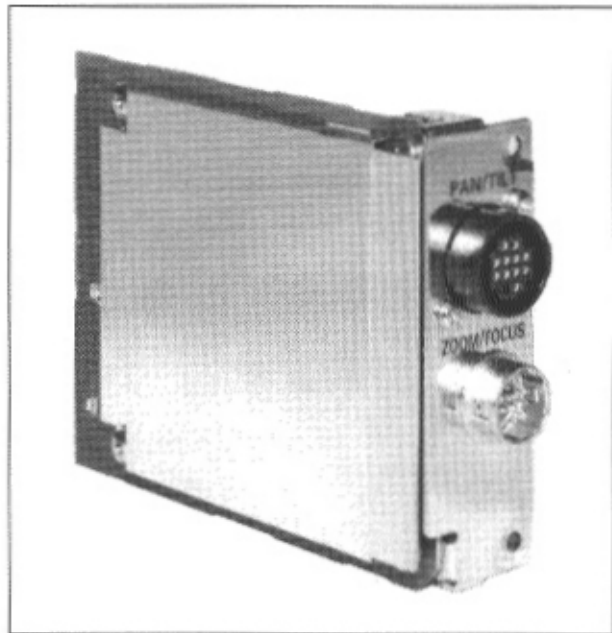

Before attempting to connect or operate this product,
please read these instructions completely
and save this manual for future use.

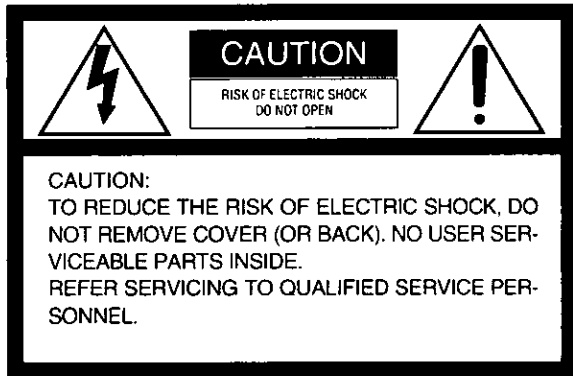

CAUTION:
 TO REDUCE THE RISK OF ELECTRIC SHOCK, DO NOT REMOVE COVER (OR BACK). NO USER SERVICEABLE PARTS INSIDE.
 REFER SERVICING TO QUALIFIED SERVICE PERSONNEL.



SA 1965

The lightning flash with arrowhead symbol, within an equilateral triangle, is intended to alert the user to the presence of uninsulated "dangerous voltage" within the product's enclosure that may be of sufficient magnitude to constitute a risk of electric shock to persons.



SA 1966

The exclamation point within an equilateral triangle is intended to alert the user to the presence of important operating and maintenance (servicing) instructions in the literature accompanying the appliance.

WARNING:
 TO PREVENT FIRE OR SHOCK HAZARD, DO NOT EXPOSE THIS APPLIANCE TO RAIN OR MOISTURE.

For U.S.A.

NOTE: This equipment has been tested and found to comply with the limits for a Class A digital device, pursuant to part 15 of the FCC Rules. These limits are designed to provide reasonable protection against harmful interference when the equipment is operated in a commercial environment. This equipment generates, uses, and can radiate radio frequency energy and, if not installed and used in accordance with the instruction manual, may cause harmful interference to radio communications. Operation of this equipment in a residential area is likely to cause harmful interference in which case the user will be required to correct the interference at his own expense.

For CANADA

This Class A digital apparatus complies with Canadian ICES-003.
 Cet appareil numérique de la classe A est conforme à la norme NMB-003 du Canada.

The information marking of this product may be found on the bottom of the unit.
 The serial number of this product may be found on the bottom of the unit.
 You should note the serial number of this unit in the space provided and retain this book as a permanent record of your purchase to aid identification in the event of theft.

Model No. _____

Serial No. _____

CONTENTS

| | |
|---|----|
| WARNING/CAUTION FOR SAFETY | 4 |
| PREFACE | 5 |
| PRECAUTIONS | 5 |
| MAJOR OPERATING CONTROLS AND THEIR FUNCTIONS | 7 |
| MOUNTING | 8 |
| CONNECTION | 10 |
| ■ In case of using a remote control box (RCB) WV-CB550 | 10 |
| ■ In case of using a remote control unit (RCU) WV-RC550 | 11 |
| ■ Connecting Receiver and Control Cable AW-CA12T11 | 12 |
| APPEARANCE | 14 |
| SPECIFICATIONS | 15 |
| STANDARD ACCESSORIES | 15 |

WARNING/CAUTION FOR SAFETY



WARNING

- **Refer all servicing to qualified personnel**

To reduce the risk of electric shock, don't remove cover or back, unless you are a qualified personnel. Refer all mountings, connections, servicing to qualified service personnel.

- **No water or moisture inside**

Do not let water or moisture into the product, or expose it to moisture, to prevent a fire and electric shock.

- If you see smoke or smell an odor from the product, if water or other foreign matter gets inside, if it is damaged by dropping, or if you find anything wrong with it, immediately stop using it.

- **Do not disassemble or modify the product to prevent a fire and electric shock.**



CAUTION

- Do not drop the product, do not expose it to strong shock, or do not step on it, to prevent a fire and injuries.
- Do not install the product at a place full of moisture and dust, which may cause a fire and electric shock.
- Do not cover the port or otherwise block ventilation during operation. Internal heat buildup can cause a fire.

PREFACE

With the lens I/F (interface) card AW-PB308 inserted into a convertible camera, AW-E300, for example, it is possible to control from a remote control box, WV-CB550, for

example, lenses with a remote control function for zooming and focusing and also a contact closure type pan/tilt head.

PRECAUTIONS

- **Power Off Before Connecting or Disconnecting Cables**

Before plugging or unplugging the cables, be sure to switch power off.

- **Handle Carefully.**

Do not drop the product, or subject it to strong shock or vibration. This is important to prevent trouble.

- **Avoid Humidity and Dust.**

Avoid using the product at a humid, dusty place because much humidity and dust will cause damage to the parts inside.

- **Operating Temperature Range**

Avoid using the product at a cold place below -10°C or at a hot place above $+45^{\circ}\text{C}$ because extremely low or high temperature will adversely affect the parts inside.

Note

Important: Combination of convertible camera with lens I/F card

- There are limitations on the versions of the cameras AW-E300 and AW-E600 to be used in combination with the lens I/F card.
- Only those cameras with the version seal on the bottom reading Ver. A or a later version (A, B, etc.) can be used in combination. (Cameras of older than Ver. A have no version seal.)

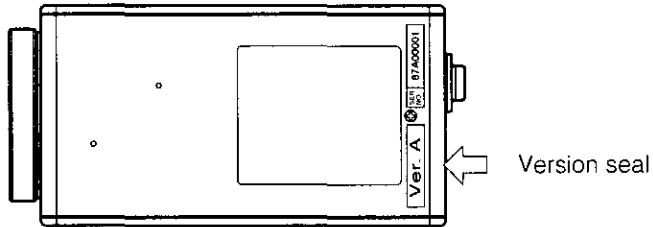

- If your camera in use is of a version unsuited to combination with the lens I/F card, consult the store where you purchased the product.

MAJOR OPERATING CONTROLS AND THEIR FUNCTIONS

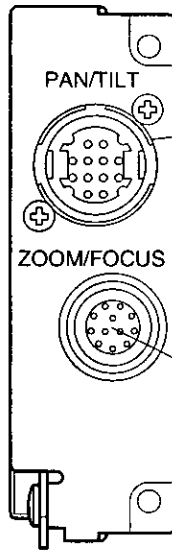

PAN/TILT connector
Connect a pan/tilt head to this connector.

ZOOM/FOCUS connector
This is a standard lens input terminal with a zoom/focus remote function.
If you are using a Panasonic pan/tilt head (AW-PH300), connect the remote cable to the LENS I/F connector on the pan/tilt head, not to the ZOOM/FOCUS connector.

MOUNTING

CAUTION

- Be sure to ask your store, where you purchased the product, for mounting.
- Disconnect the camera power connector before mounting.
- Before handling the card, touch a metal part of the camera to discharge the static from the human body.
An anti-static wrist strap is recommended for added safety.
If you touch the card while you are still charged with static, it may cause trouble.
- Keep the metal parts of the card free of contact with other metal parts.

- (1) Switch the camera off, and disconnect the power connector and other cables from the camera.
- (2) Loosen the four screws on the rear of the camera and remove the rear panel.
- (3) Loosen the two screws for the option card slot and remove the cover.
- (4) Insert the Lens I/F card along the guide rail at the bottom of the camera and the tab above.
Insert it securely all the way.
- (5) Tighten the two card setscrews securely.
If you have lost the screws, use the screws (6 mm long) supplied as accessories.
- (6) Fasten the rear panel with the four screws.
If you have lost the screws, use the screws (8 mm long) supplied as accessories.
- (7) Plug the cables back as necessary, connect the power connector, then switch power on.

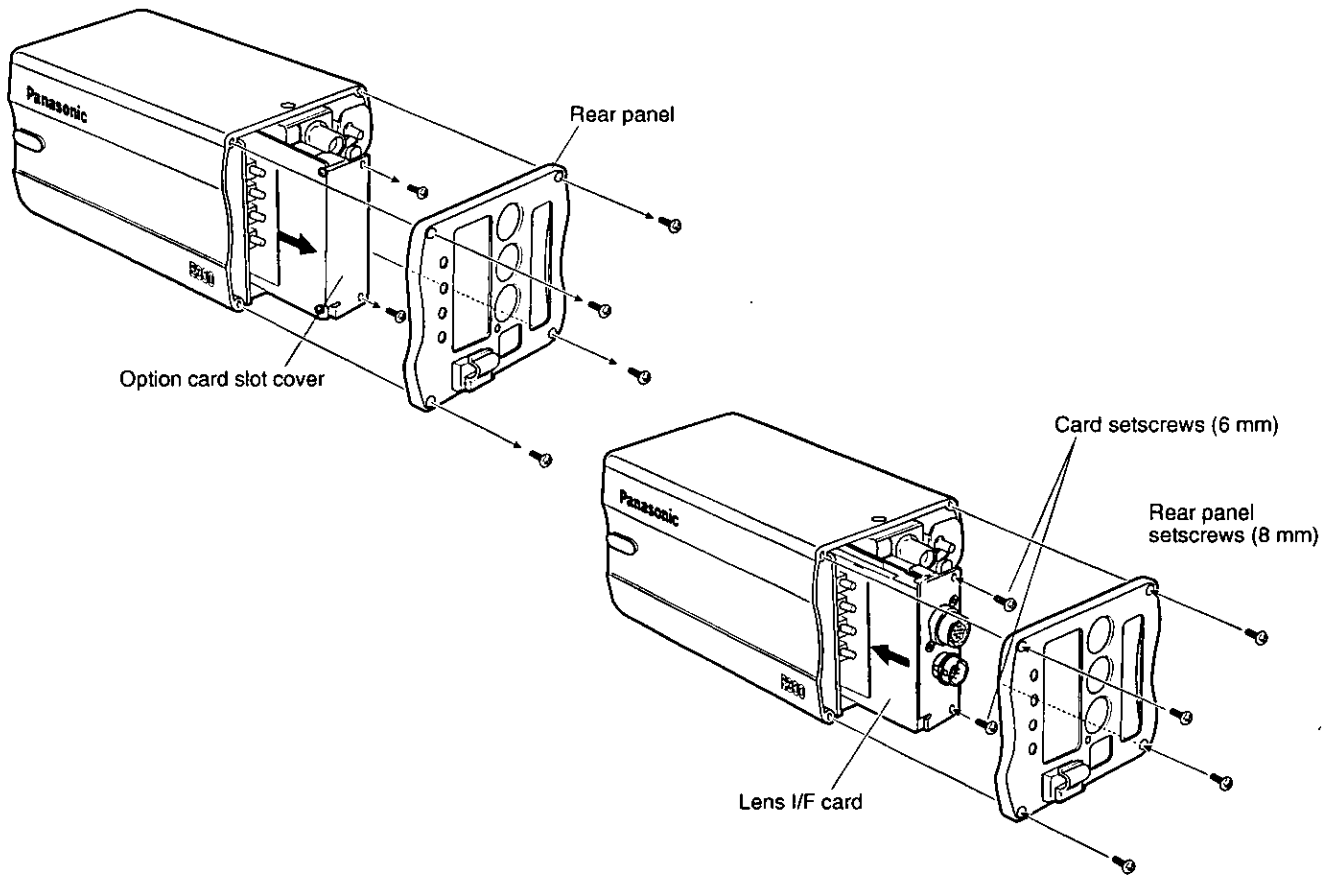

CONNECTION

- Before cable connection, switch power off.
- Use the AC adaptor AW-PS505 for power supply.
- The indoor receiver WV-RC100 or outdoor receiver WV-RC150 is necessary.
- Connect the camera to the receiver with the control cable AW-CA12T11. (See page 12.)
- For details on connecting individual devices, refer to the respective operating instructions.
- For details on operating individual devices, refer to the respective operating instructions.

■ In case of using a remote control box (RCB) WV-CB550

- Connect RCB to the camera with three coaxial cables (video signal, G/L signal, control signal) (5C-2V or equivalent, 300 m in maximum extension length).

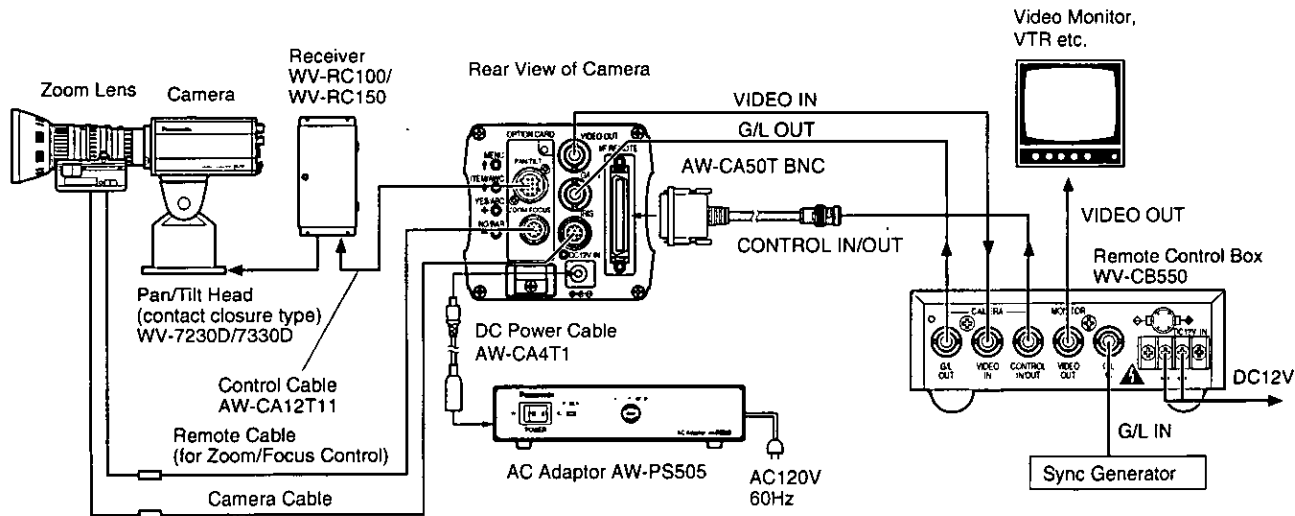

■ In case of using a remote control unit (RCU) WV-RC550

- Connect RCU to the camera with the RCU cable AW-CA50A26 (15 m) (300 m in maximum extension length).
- To extend the RCU cable, use the cable joint adaptor WV-CA26T26 and studio cable WV-CA26U15 (15 m), or WV-CA26U30(30 m) or WV-CA26U100 (100 m).
- A remote control unit for zoom lens and pan/tilt head is also necessary.

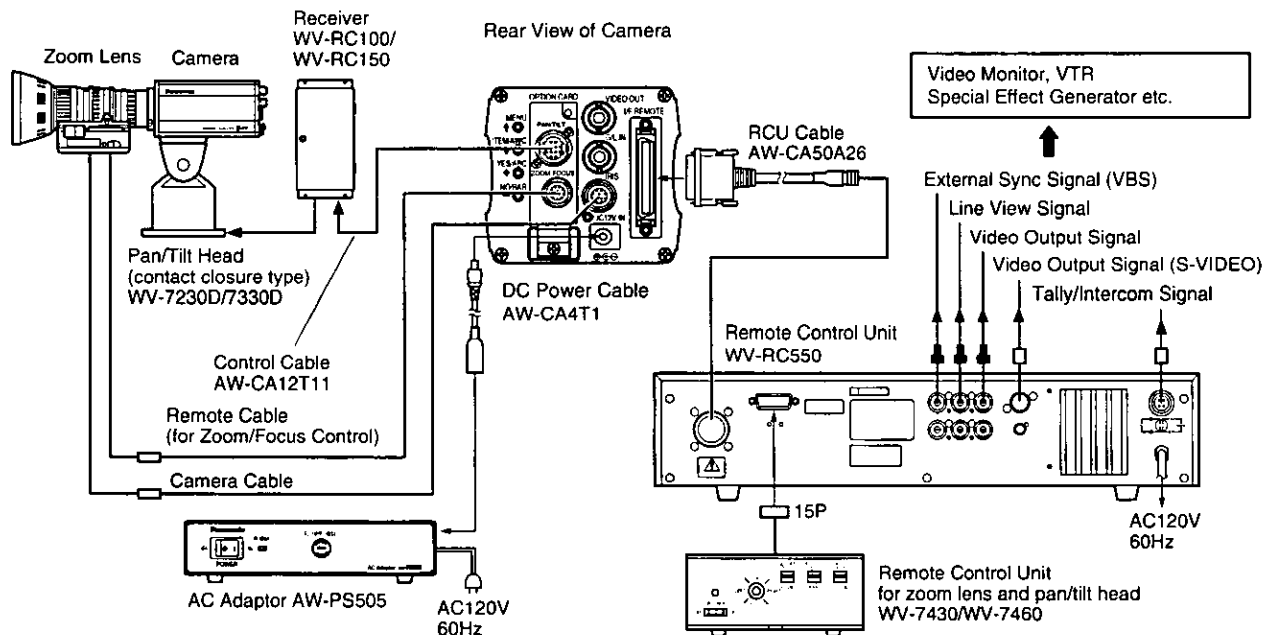

■ Connecting Receiver and Control Cable AW-CA12T11

- The control cable AW-CA12T11 is provided with a circuit board and spacers.
- Assemble the circuit board and spacers with the receiver WV-RC100 (WV-RC150), and connect the control cable to that circuit board.

① Remove the two screws on the connector board shown from inside the receiver.

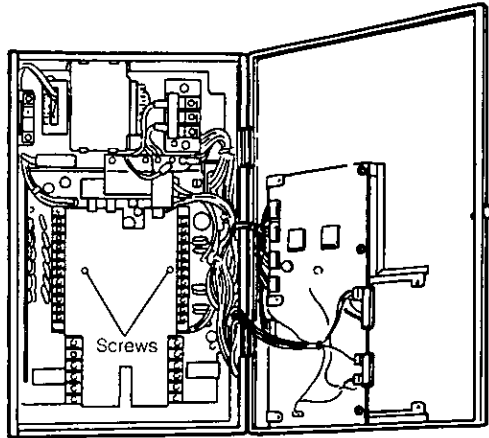

② Fit the two spacers on the connector board and fasten the circuit board with the screws removed in Step ①.

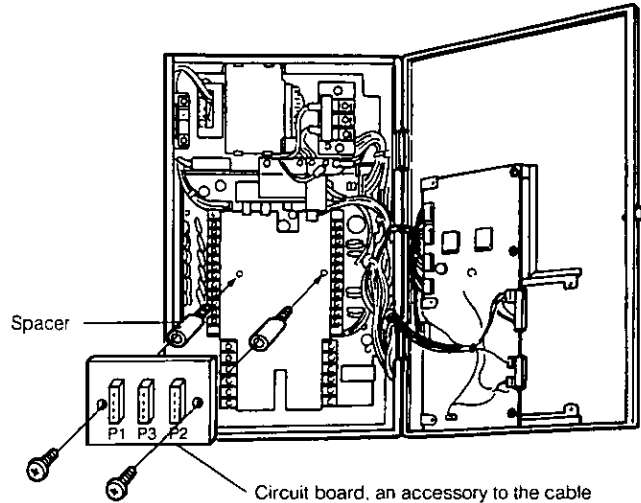

- ③ Disconnect the wired connector that is connected to connector CN4 on the process circuit board, and connect it to connector P3 on the installed circuit board. (Either cut or remove the band that binds the wires.)
- ④ Remove the wired connector that is connected to connector CN3 on the process circuit board, and connect it to connector P2 on the installed circuit board.

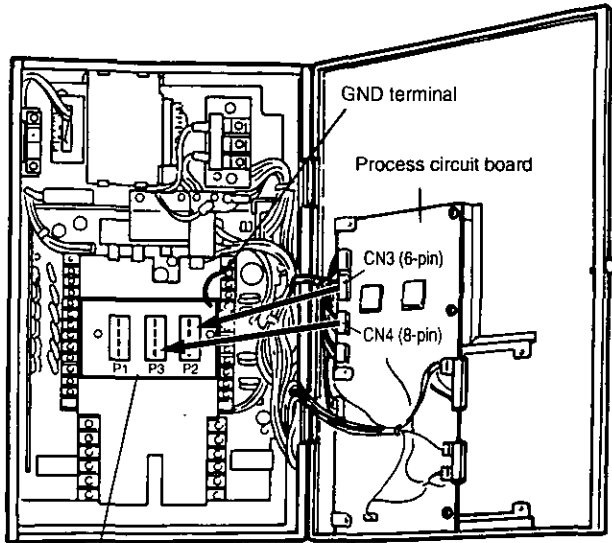

Circuit board, an accessory to the cable

- ⑤ Connect the wire on the circuit board to the receiver's GND terminal.
- ⑥ Connect the control cable AW-CA12T11 to connector P1 on the circuit board.

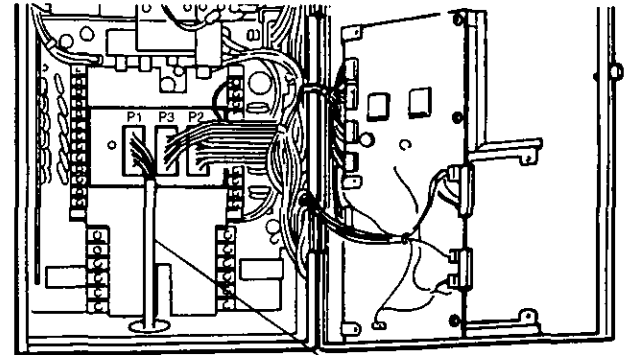

Control cable AW-CA12T11

↓ Connect the 12-pin connector to the PAN/TILT connector on the lens I/F card.

APPEARANCE

Unit: mm (inch)

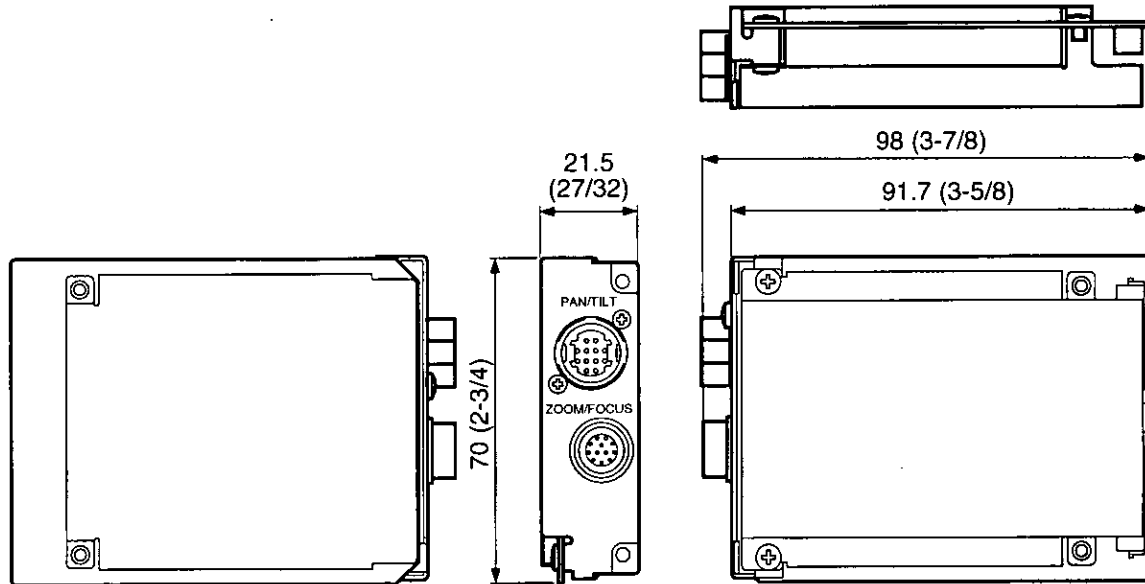

SPECIFICATIONS

| | |
|------------------------|--|
| Source voltage: | 12 V DC (supplied from camera) |
| Power consumption: | 0.02 W |
| Operating temperature: | -10°C to +45°C (14°F to +113°F) |
| Operating humidity: | 30 % to 90 % |
| Dimensions: | 21.5 (W) x 70 (H) x 98 (D) mm [27/32" x 2-3/4" x 3-7/8"] |
| Weight: | 75 g |

Weight and dimensions indicated are approximate.
Specifications are subject to change without notice.

STANDARD ACCESSORIES

| | |
|-------------------------|--------|
| Screw (6 mm long) | 2 pcs. |
| Screw (8 mm long) | 4 pcs. |

Panasonic

PANASONIC BROADCAST & DIGITAL SYSTEMS COMPANY
DIVISION OF MATSUSHITA ELECTRIC CORPORATION OF AMERICA

Executive Office: 3330 Cahuenga Blvd W., Los Angeles, CA 90068
(323) 436-3500

EASTERN ZONE: One Panasonic Way 4E-7, Secaucus, NJ 07094 (201) 348-71
Mid-Atlantic: One Panasonic Way 4E-7, Secaucus, NJ 07094 (201) 348-71
Southeast Region: 1225 Northbrook Parkway, Ste 1-160 Suwanee, GA 30024
(770) 338-6845

Central Region: 1707 N Randall Road E1-C-1, Elgin, IL 60123 (847) 468-5200

WESTERN ZONE: 3330 Cahuenga Blvd W., Los Angeles, CA 90068 (323) 436-
Dallas Region: 6226 Abington Way, Houston, TX 77008 (713) 802-2726

Government Marketing Department: 52 West Gude Drive, Rockville, MD 20850 (301) 738-3840

PANASONIC CANADA INC.

5770 Ambler Drive, Mississauga, Ontario, L4W 2T3 (905) 238-2115

PANASONIC SALES COMPANY

DIVISION OF MATSUSHITA ELECTRIC OF PUERTO RICO, INC.

San Gabriel Industrial Park, 65th Infantry Ave., KM9.5 Carolina, Puerto Rico 00630 (809) 750-4300